

Fisheries Survey Vessel (FSV) Capabilities and Challenges



October 21, 2015



Office of Marine and Aviation Operations

NOAA Marine Operations: *2015 Trends/Observations*

Increased Arctic Requirements

≈ 25% total fleet activity in 2015

≈ 10% prior years

↑ Requirements to Support UAS/UMS

- development of new operational procedures/ training
- coordination with FAA

First Autonomous Surface Vehicle certified for Hydrographic Survey

- force multiplier for productivity

Crewing challenges (Licensed Engineering Officers

Ship's break! 3 Emergency Dry Docks



Reuben Lasker (FSV-6)

Delivered November 8, 2013
Norfolk, VA



Reuben Lasker

General Characteristics

- LOA: 63.6m (208.7 ft)
- Breadth: 15m (49.2 ft)
- Draft: 9.05m (29.7 ft)
- Displacement: 2524 MT
- Cruising Speed: 12 kts
- Range: (10,000nm)
- Endurance: 40 days
- Total Berths: 39
- 2 X3512 DG – 1360 kW
- 2 X C32 DG – 910 kW
- 2 X 1125 kW DC Motors – 134 RPM
- 1 X Tees Thruster White Gill - 726 kW
- 1 X 5 bladed propeller – 4.3m (14.1 ft) dia



Unique Characteristics

- Mast design altered from previous FSV
- Aft deck arrangements
 - Trawl ramp
 - Net Reel
- Diesel generators CAT C32 vice previously used 3508
- Generator mounting configuration
- Acoustic sensors (MS-70; SX-93)
- Electric vice hydraulic winches



Mast Design



Previous Mounting Design

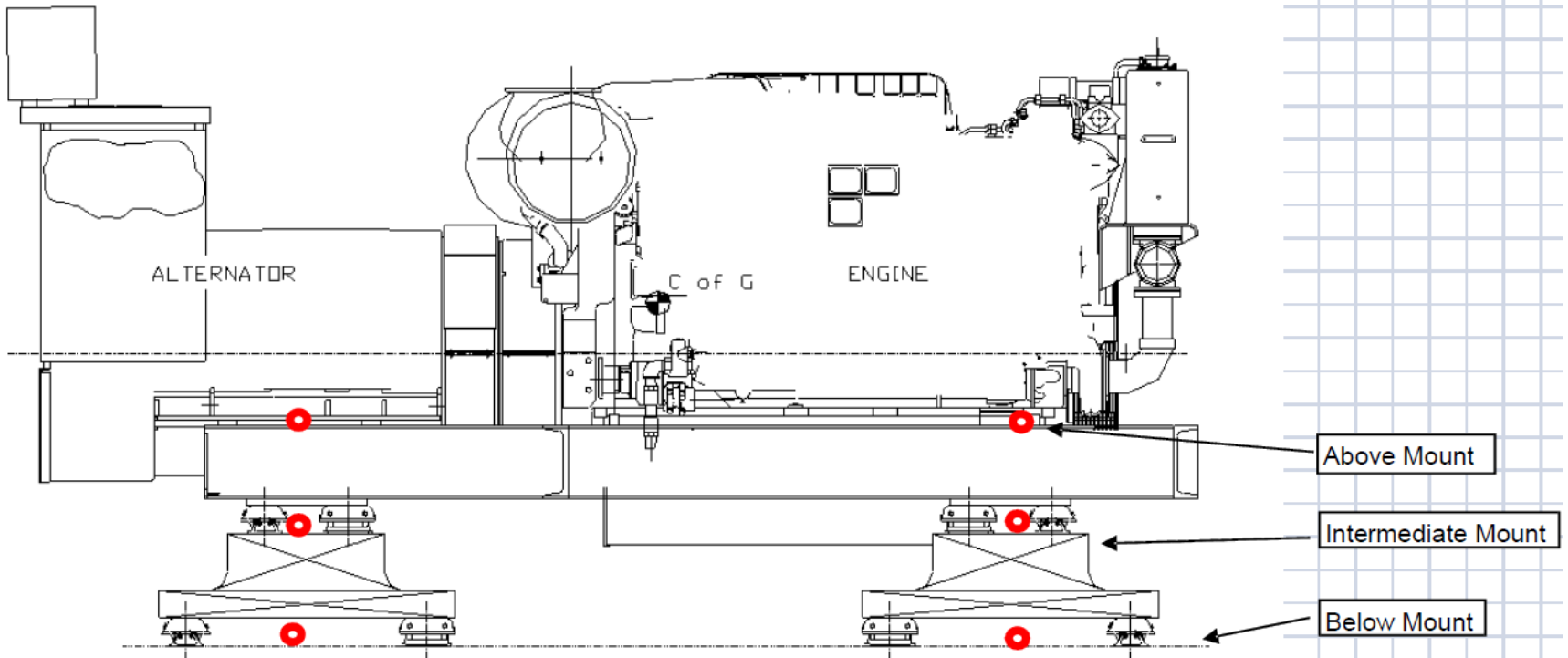

Modified Mounting Design



Challenges

- Acoustically quieting a vessel
 - Requires builders to apply systems engineering approach to acoustics
 - Impacts all areas of design and construction
 - Builders not necessarily familiar with acoustic quieting
 - If the criteria are exceeded, they are difficult to resolve



Challenges

- Power Quality
 - Critical to equipment and scientific sensors
 - Difficult to diagnose and resolve once observed
 - No clear data demonstrating harmonic distortion impacts
 - Technology constantly evolving



Challenges

- Regulatory Bodies
 - Requirements change
 - Technical reviews can miss key details
 - Surveyors' differing interpretations
 - Surveyors inspect systems where they don't necessarily have expertise
 - Example: annual survey



Challenges

- New Technology
 - Incorporating innovative and cutting edge technology into a vessel design is challenging
 - Shipyards aren't always motivated to bring in necessary expertise
 - Specifications are difficult to write in such a way to keep up with changing technology
 - New capabilities require different skill sets than the legacy platforms



Challenges

- Shipbuilding
 - Research vessels are very complex
 - Instrumentation (sensors, sonars, etc)
 - Multi-mission capabilities
 - Ideally, mission profile and capabilities would drive vessel design
 - Funding for new construction has been sporadic





Questions ?

