



IRSO 2015

First sea trials of  
HROV Ariane

The new hybrid vehicle developed by Ifremer

2010 : kickoff

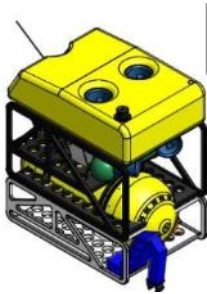

Concept study

December 2014 : 1st sea trial

Sept-Nov 2014 : pool and harbour tests



Tests

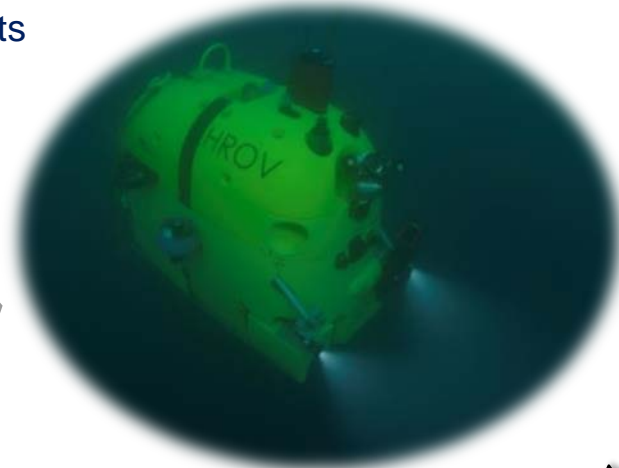

Mid 2011

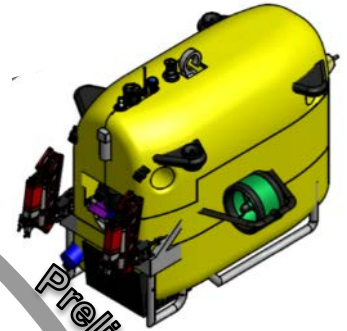

Preliminary

End 2012



Detailed study



Build phase

Integration



April 2014



End 2013



# HROV Ariane : 1st sea trials

Cruise	Date	Vessel	Results
ESSHROV1	December 2014	N/O Le Suroît	5 dives
ESSHROV2	March 2015	N/O Le Suroît	10 dives
ESSHROV3	May 2015	N/O L'Europe	7 dives

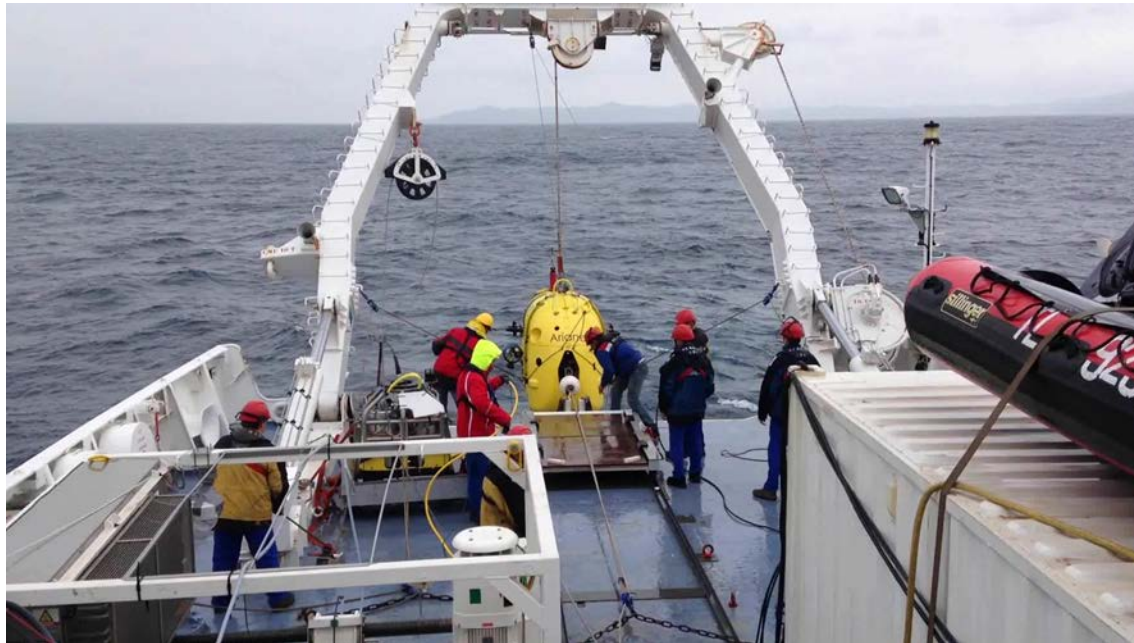

- Validation of deployment, navigation, manoeuvrability
- 22 Dives mainly in ROV mode
- Tests of first payloads (manipulators and camera)

# Hybrid ROV – a new concept of underwater vehicle



## ROV : remote operation

- Cable : power supply & real time control
- Maneuverability constraints

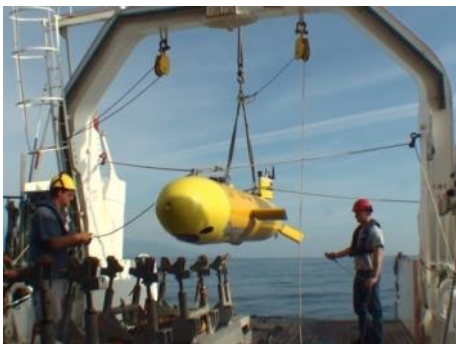

## AUV : survey operation

- Untethered autonomous vehicle
- On-board power supply
- No real time control

## Hybrid-ROV :

### Self powered underwater vehicle

- fiber optic tether → ROV mode
- untethered → AUV mode



# Hybrid ROV Ariane : overview

## Most innovative feature : operated from light vessels

Non DP capable light vessel available

- ➔ Reduced operational cost
- ➔ Easy and cost-effective access to ship time  
(opportunity vessels)

## Ariane missions :

- Daily work cycle, mostly coastal, up to 2500m depth
- Close-up inspection, Sampling and light tools manipulating, optical imaging, acoustic mapping
- Perform tasks on all sorts of seabed morphology, emphasis on canyons, cliffs and steep inclines

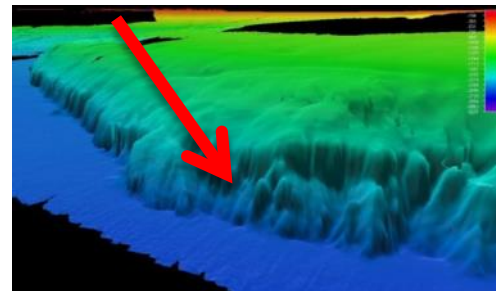
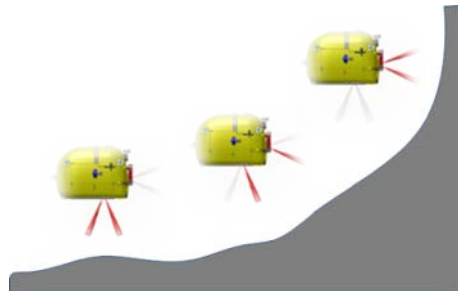

# Hybrid ROV Ariane : vehicle

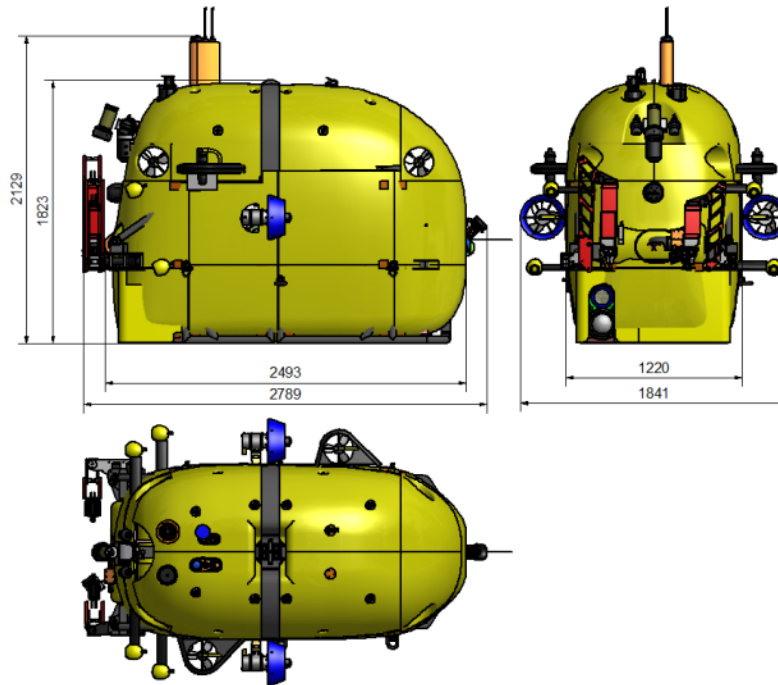

- **Mass** : between 1,6 and 1,8 tons depending on payload configuration
- **Payload** : up to 250kg (including manipulators and basket)
- **Power supply** : 2 Li-ion batteries in pressure housing
  - 14kWh battery dedicated to thrusters and lights
  - 6kWh battery dedicated to electronic and safety devices
- **Main actuators** :
  - Main propulsion : 2 tilting thrusters → speed : 0-2 knots
  - 2 vertical and 2 lateral thrusters
  - 20 liter reversible ballast

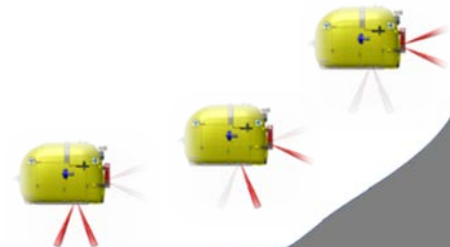

# Hybrid ROV Ariane : vehicle



- USBL beacon
- Wifi, DGPS Gonio-beacon
- Flasher
- Acoustic modem



1.8 tons

2500 m max depth

4 to 10 hours endurance

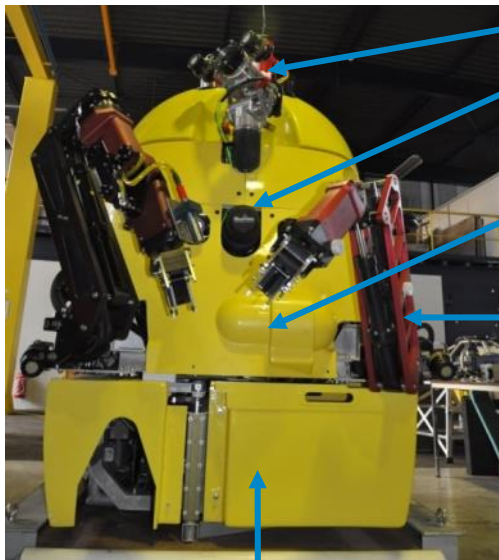

- Main P&T HD cam
- FWD looking sonar

Frontal DVL

5 and 7 function arms

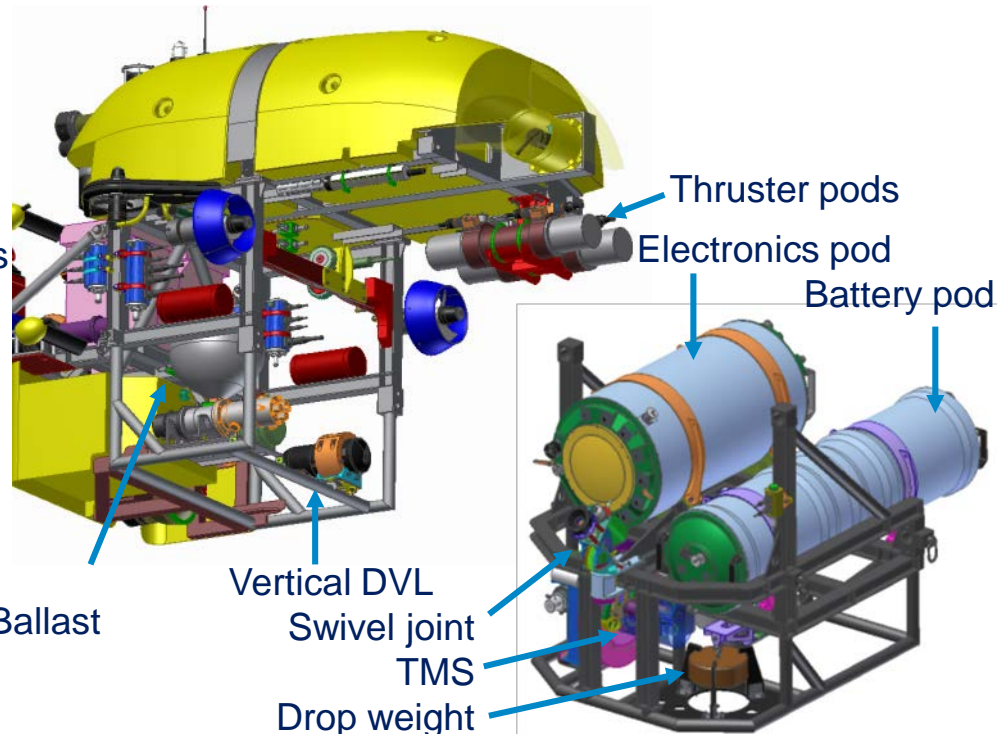

Thruster pods

Electronics pod

Battery pod

Ballast

Vertical DVL

Swivel joint

TMS

Drop weight

- Motorised payload tray
- Tilting digital camera
- Biological sampling tools

# HROV Ariane's innovative deployment – ROV mode

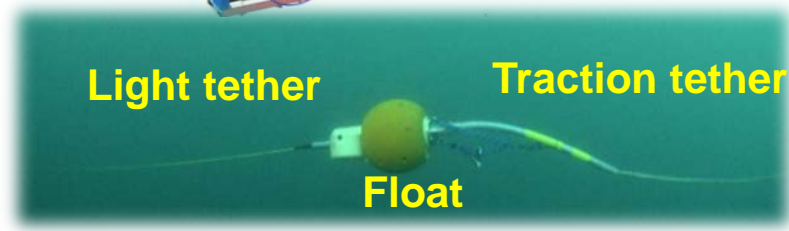
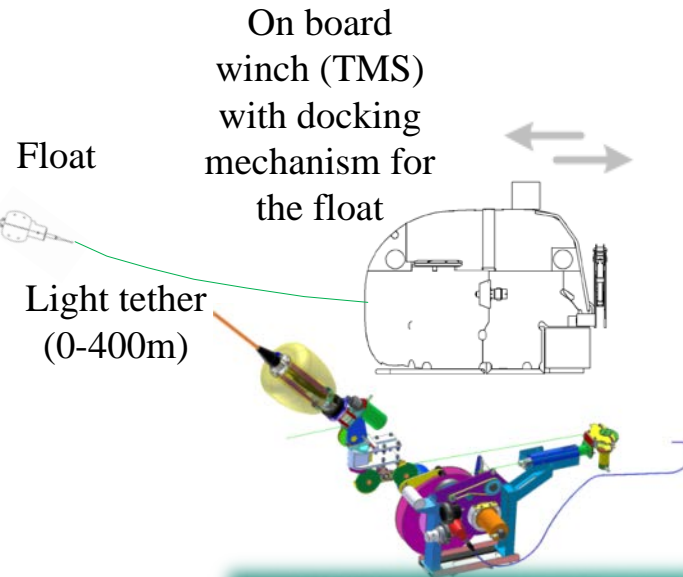
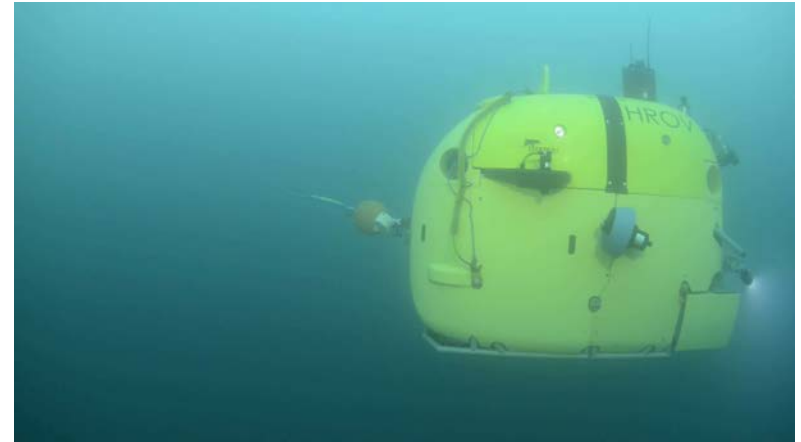
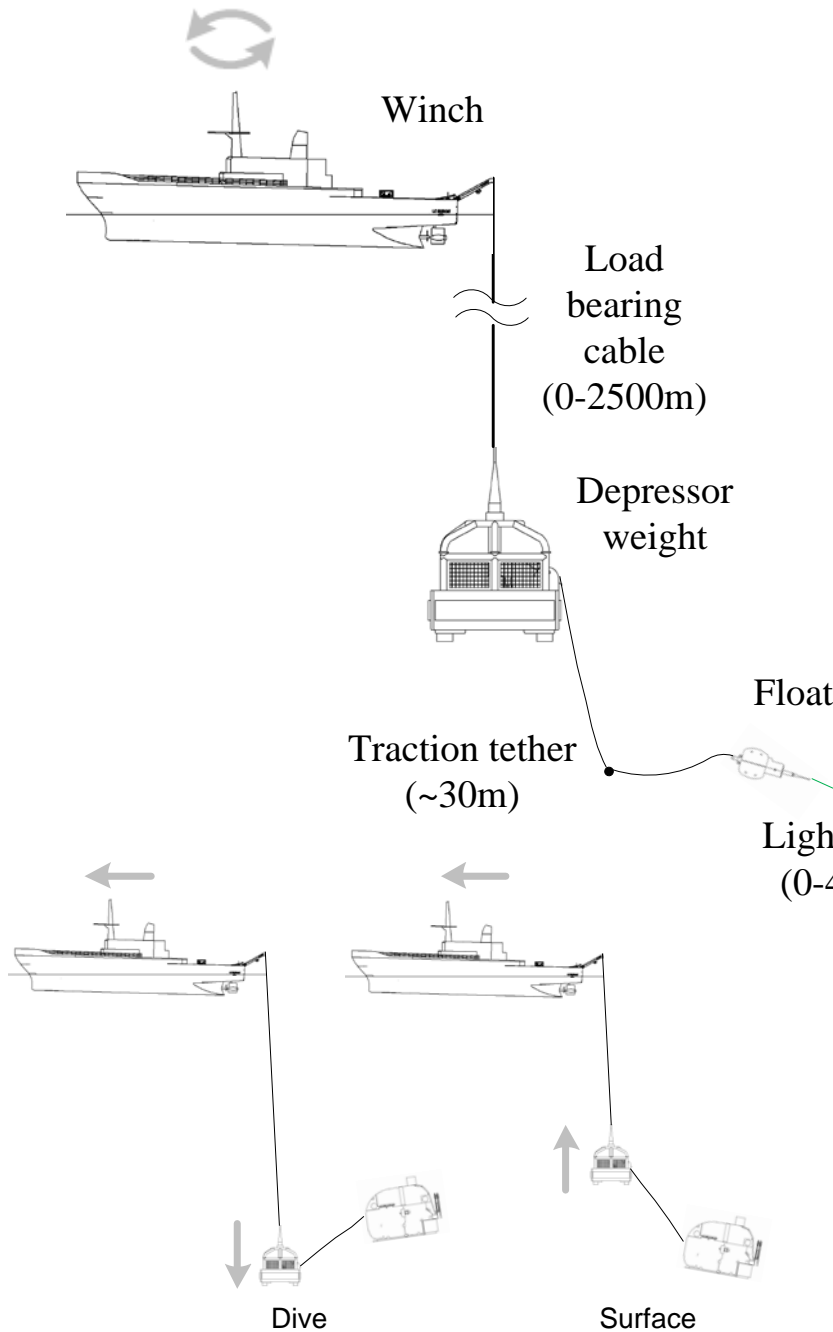

# HROV – AUV mode

## 2 AUV modes :

- Safety mode in case of ROV mode failure
- Nominal AUV mode (tested in 2016)

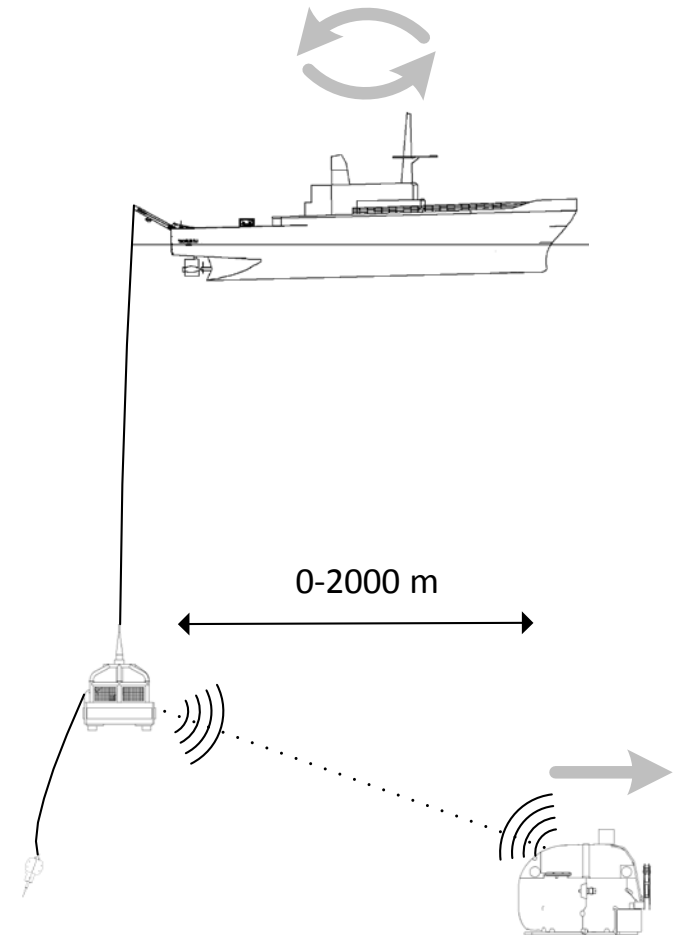
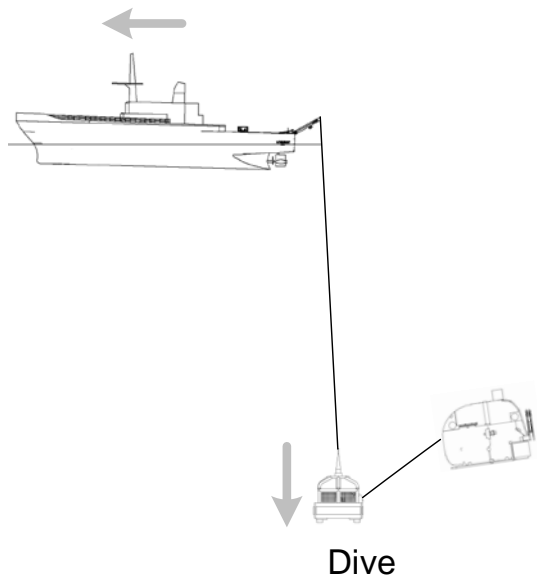

Acoustic modem on the depressor weight

➔ Optimisation of the acoustic communication

# Deployment from N/O L'Europe

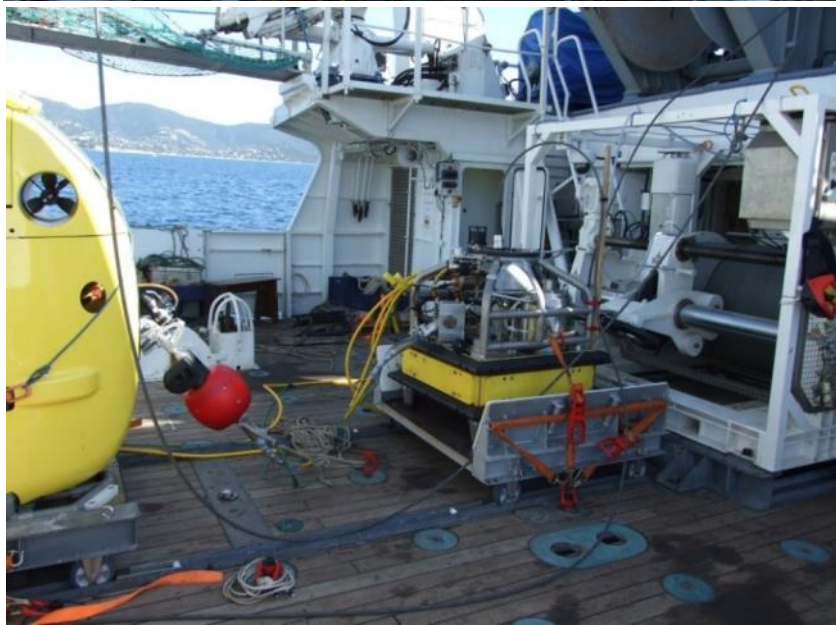
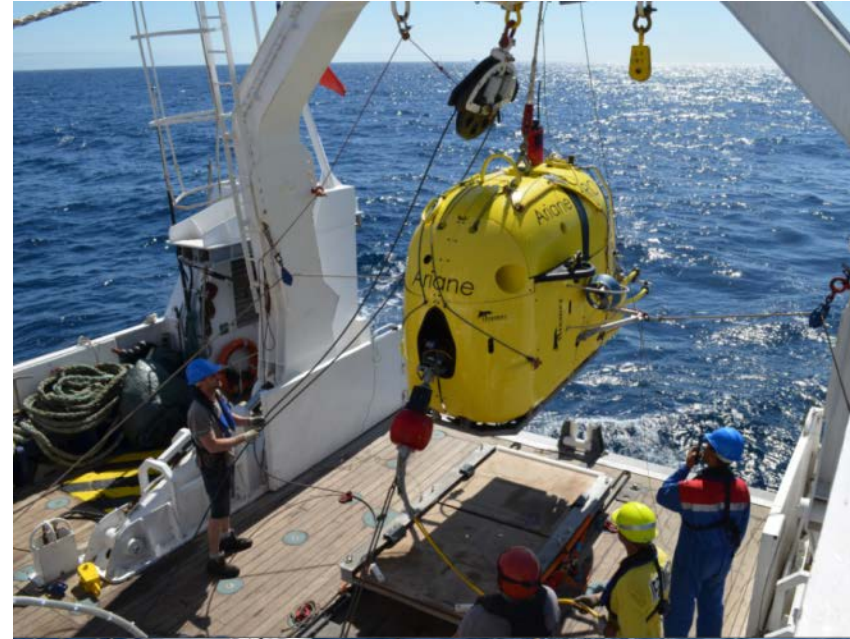
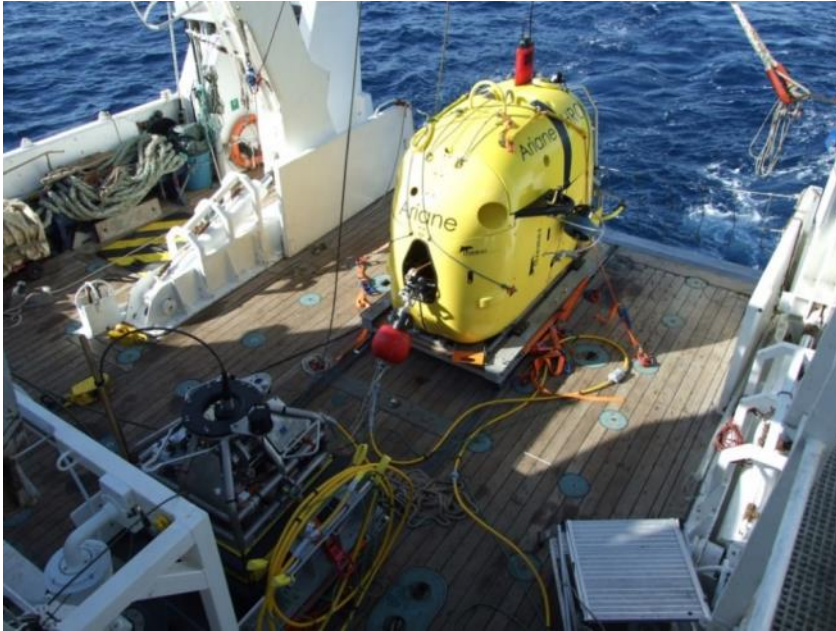

# Piloting Hybrid ROV Ariane



**Compact cockpit**

**3 operators :**

- Pilot
- Copilot
- Scientist



# Navigation on steep slopes

- ✓ 4 dives on cliff or steep slope
- ✓ 2 DVLs used for navigation

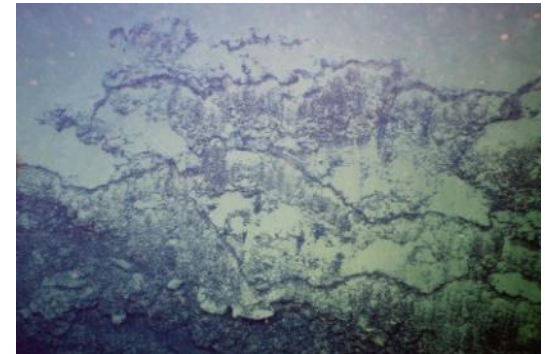
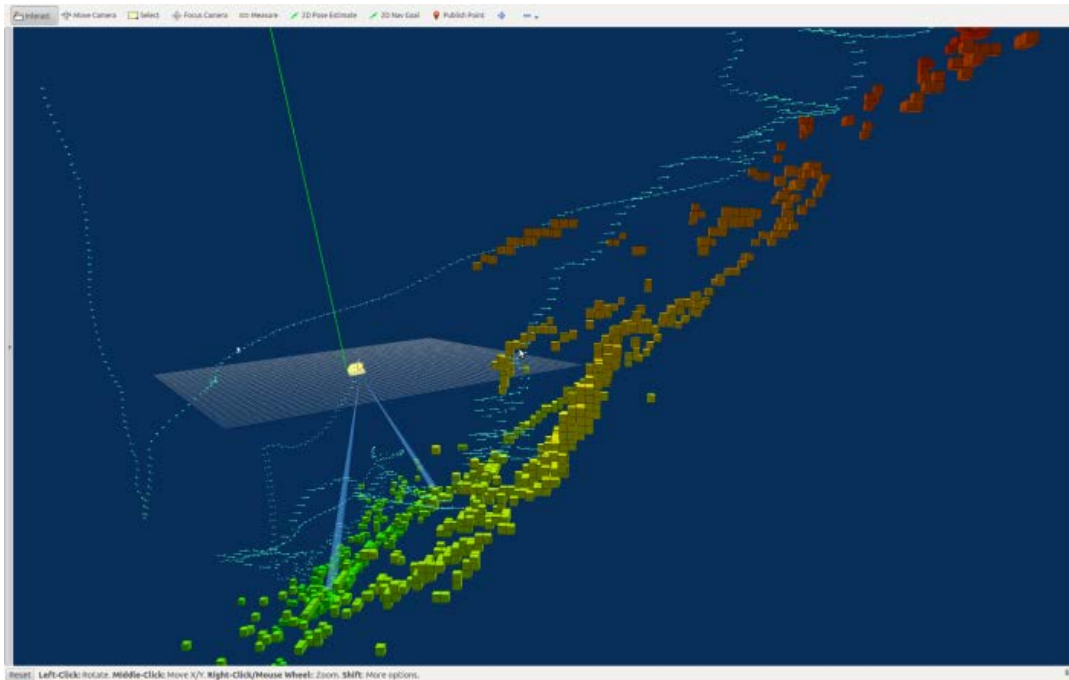
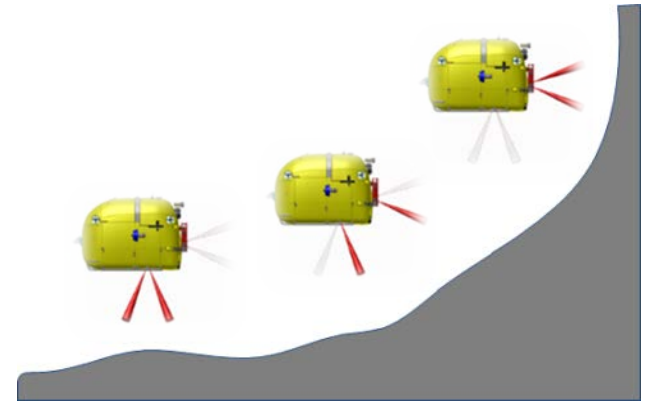

# First tests of manipulators

- ✓ Manipulators configuration:
  - 7 function electric arm
  - 5 function electric arm
- ✓ First tests done only with the 5 function arm

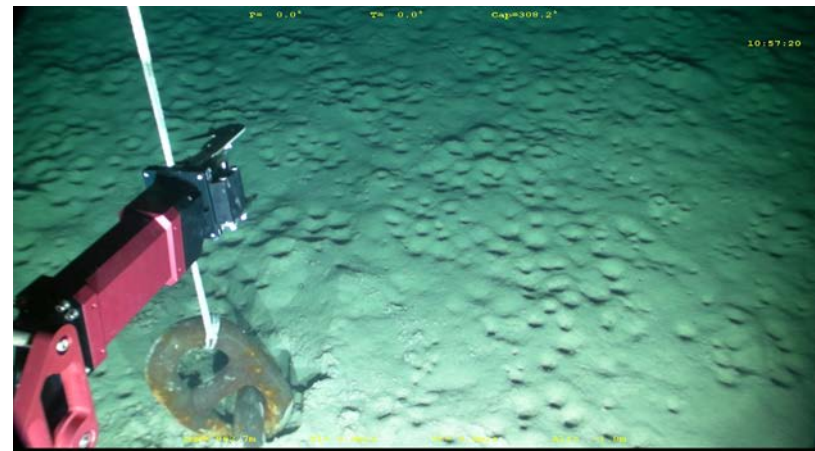
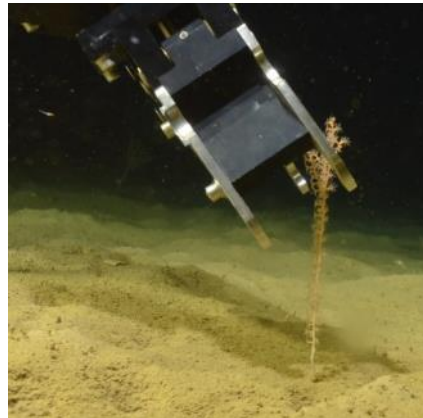
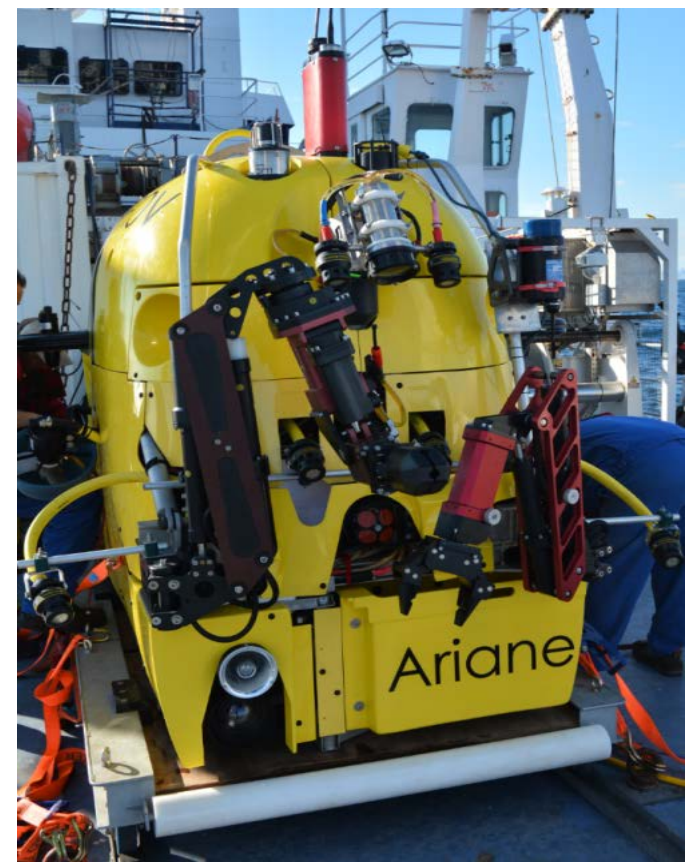

# First test of digital camera

Digital tilt-camera

Tested without flash

2D mosaïc :

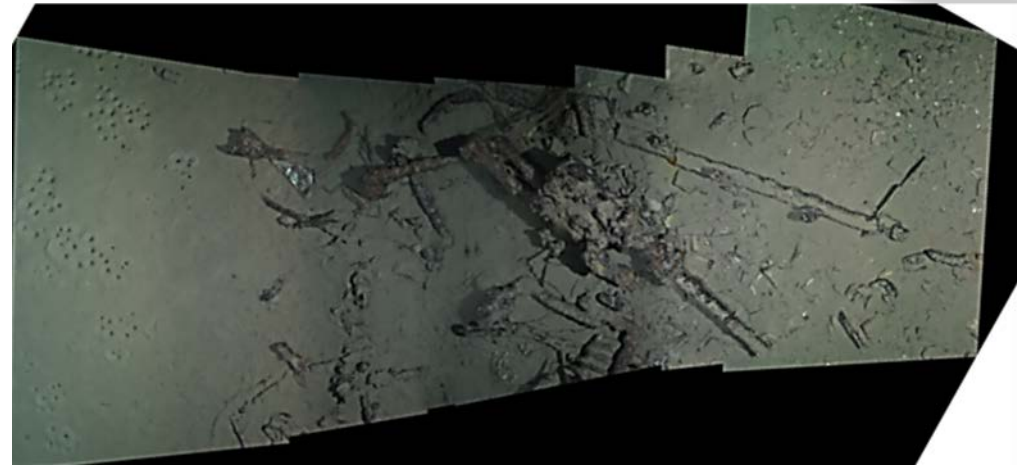
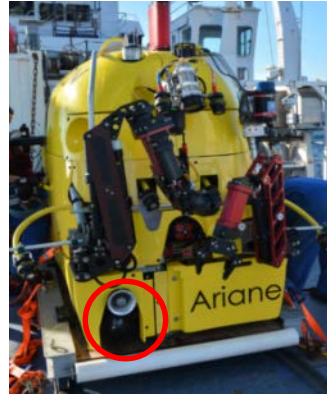
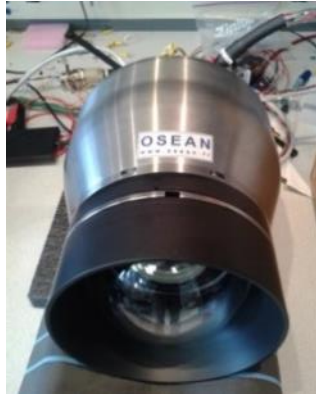
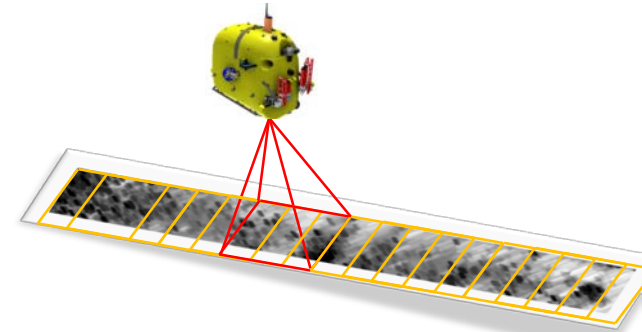

# Inspection and 3D mosaïc

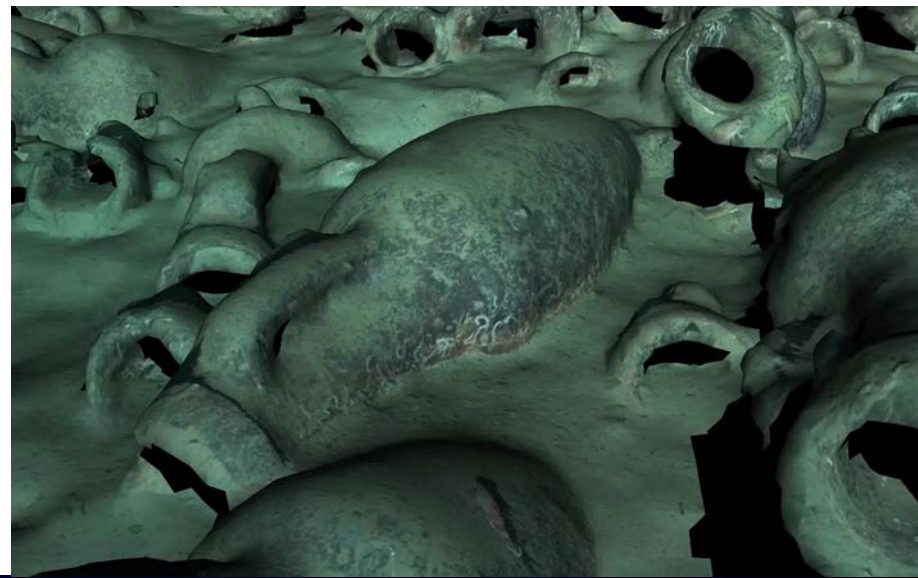

# Next steps

## → 2016 :

- ❑ HROV validation in intervention configuration (sampling payloads, manipulators, camera)

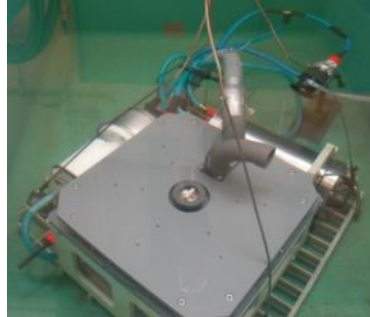

- ❑ AUV mode validation
- ❑ First scientific cruises

## → Early 2017 :

- ❑ HROV validation in cartography configuration for acoustic and optic survey (payloads : SMF EM2040 and digital camera)

