



Scripps zero-emission hydrogen hybrid research vessel

Dr. Bruce Appelgate
Associate Director,
Scripps Institution of Oceanography
bappelgate@ucsd.edu

Presentation Overview

- Why zero-emission ships?
- Feasibility of zero emissions
- Zero-emission hybrid power
- Coastal class research vessel

Acknowledgments: We are grateful for support and collaboration



Research vessels operated by Scripps Institution of Oceanography are part of the US Academic Research Fleet, a major facility supported by the National Science Foundation under awards that include OCE-1827444, OCE-1827415, OCE-1827383, OCE-1923051, and OCE-1823600.



This material presented here is based upon work supported by the Office of Naval Research under Awards N00014-22-1-2765 and N00014-16-1-2745. Any opinions, findings, and conclusions or recommendations expressed in this publication are those of the author and do not necessarily reflect the views of the Office of Naval Research.



This material is based upon work supported by the U.S Department of Transportation Maritime Administration (MARAD) Maritime Environmental and Technical Assistance (META) program.

Download the full reports:
maritime.sandia.gov





R/V *Robert Gordon Sproul*

Built: 1981

Length: 125 feet (38 m)

Crew: 5 Scientists: 12

Endurance: 14 days

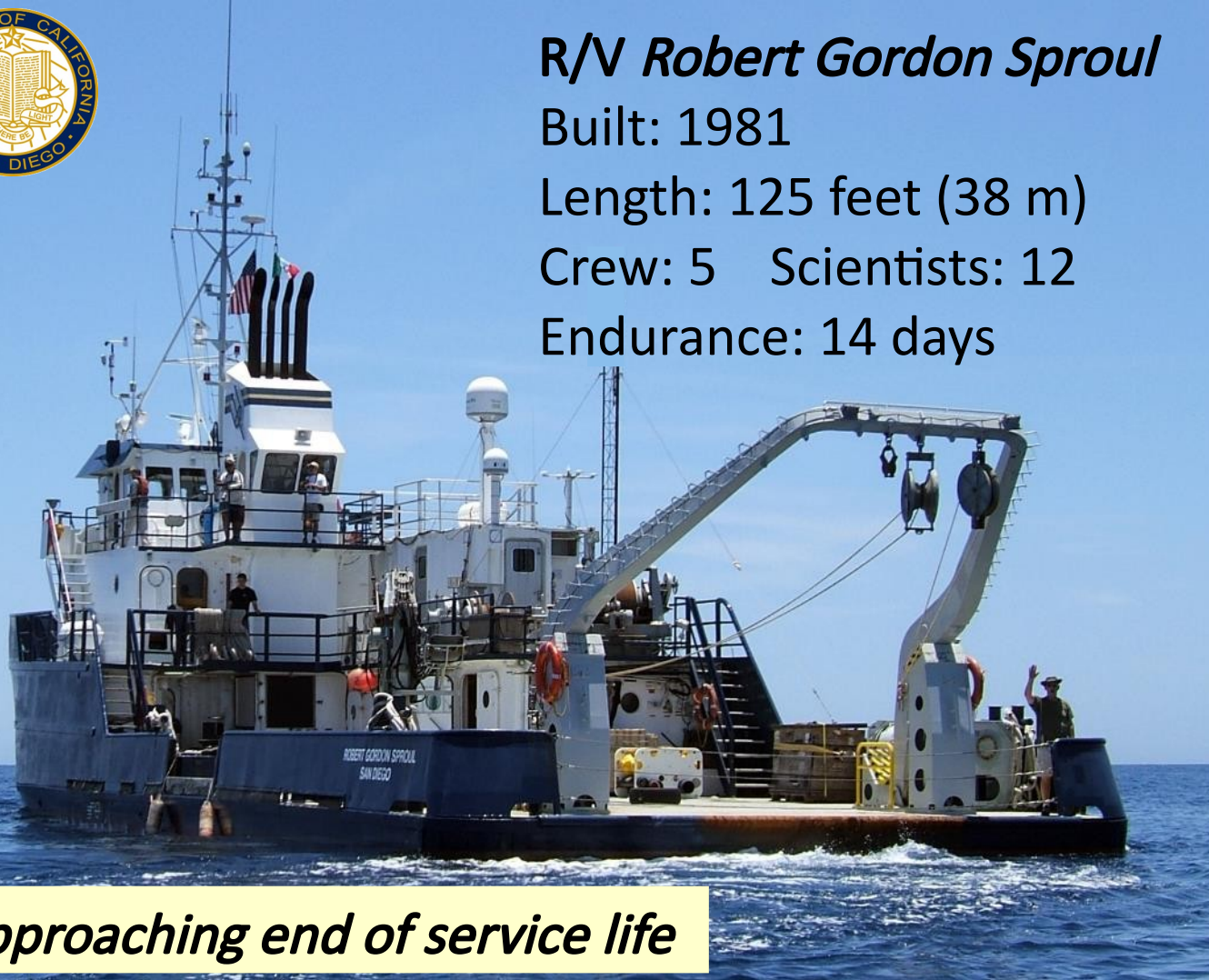

Sally Ride



Roger Revelle

Beyster



Approaching end of service life

Ship Tracks 1956-2021

Scripps Institution of Oceanography

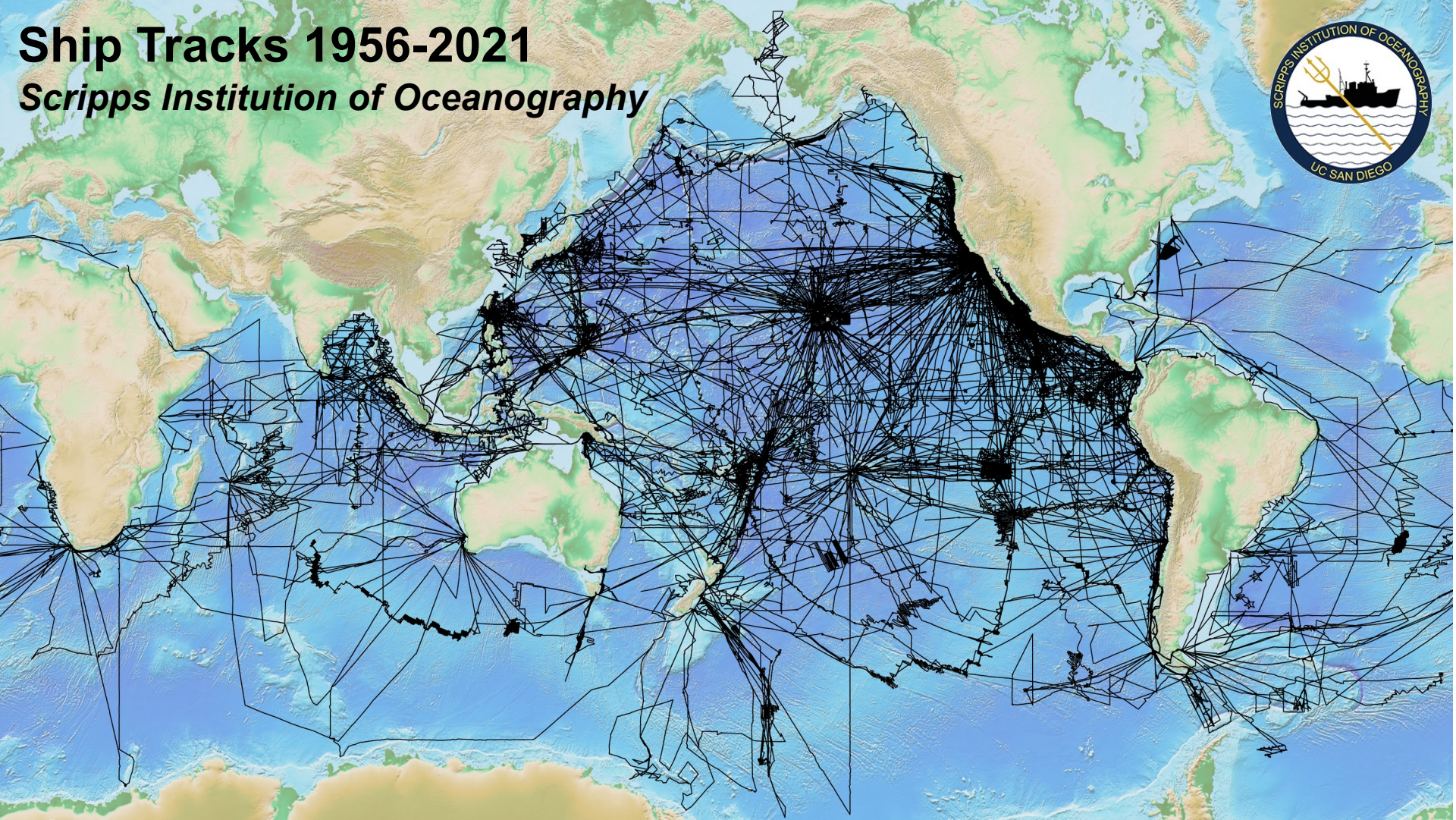

Ships pollute the Earth with CO₂ (a greenhouse gas)

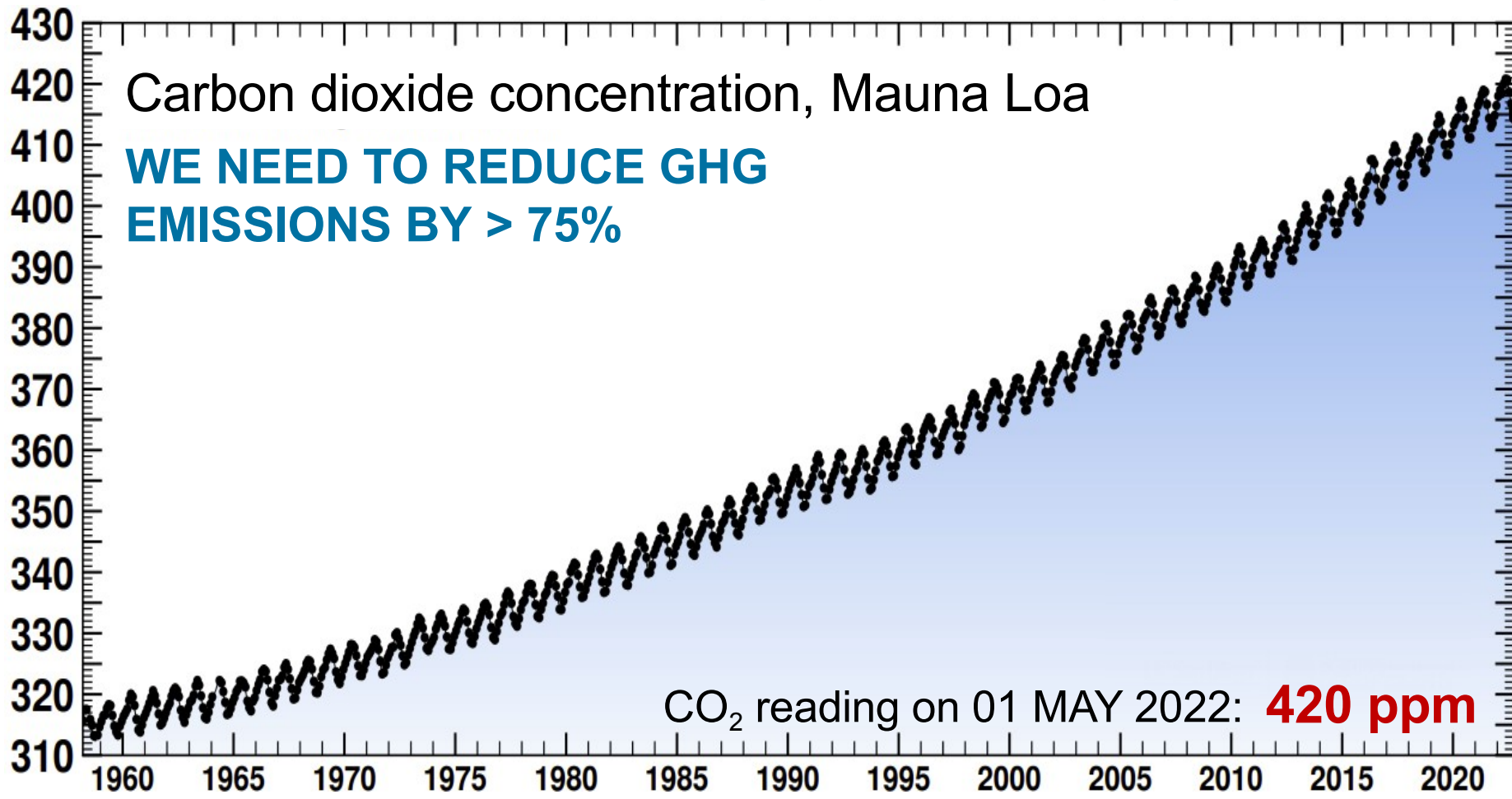

Ships pollute the Earth with CO₂ (a greenhouse gas)

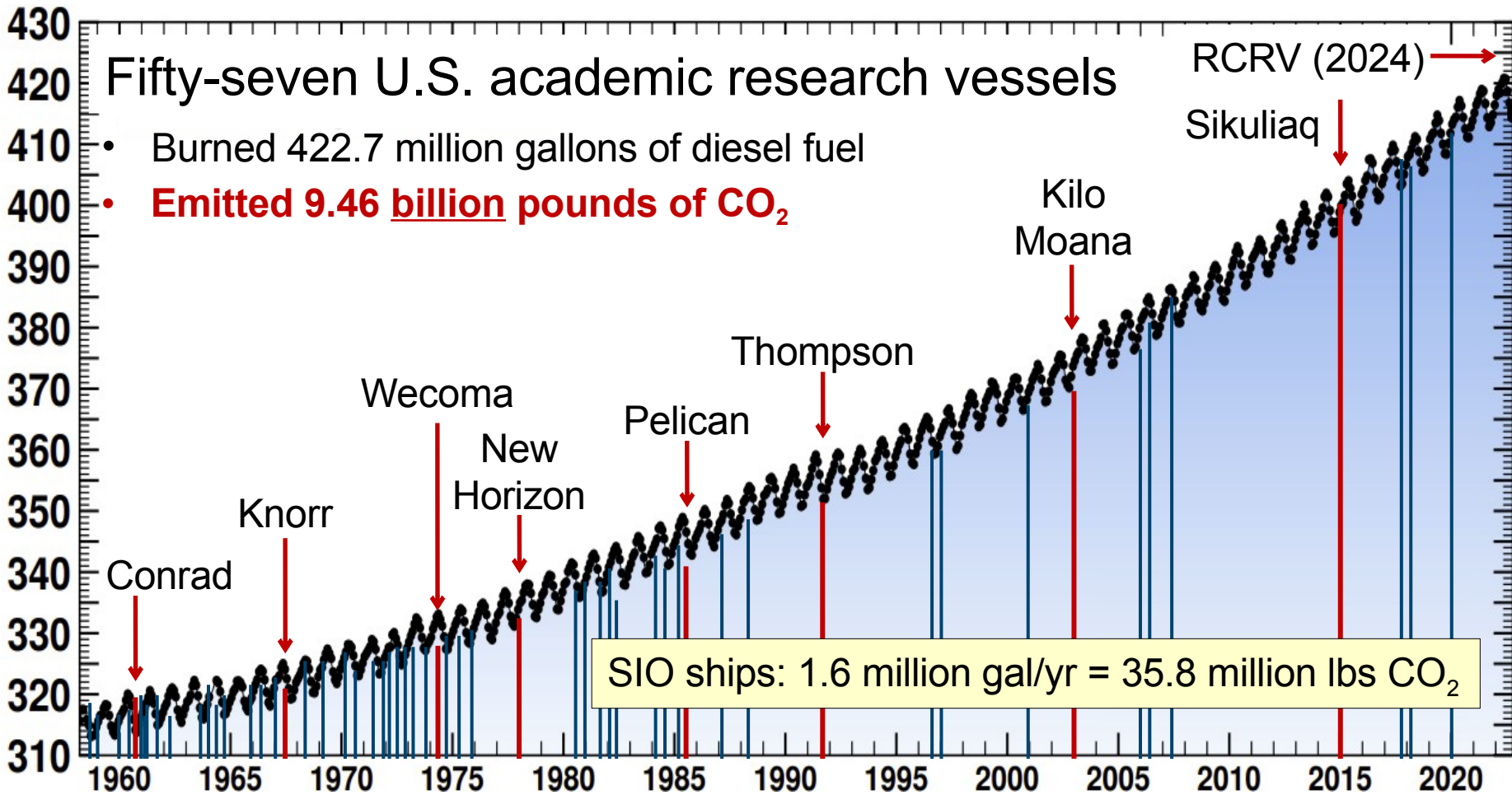

Ship Tracks 2009-2016

R/V Robert Gordon Sproul

Avila Beach

Santa Barbara

Los Angeles

San Diego

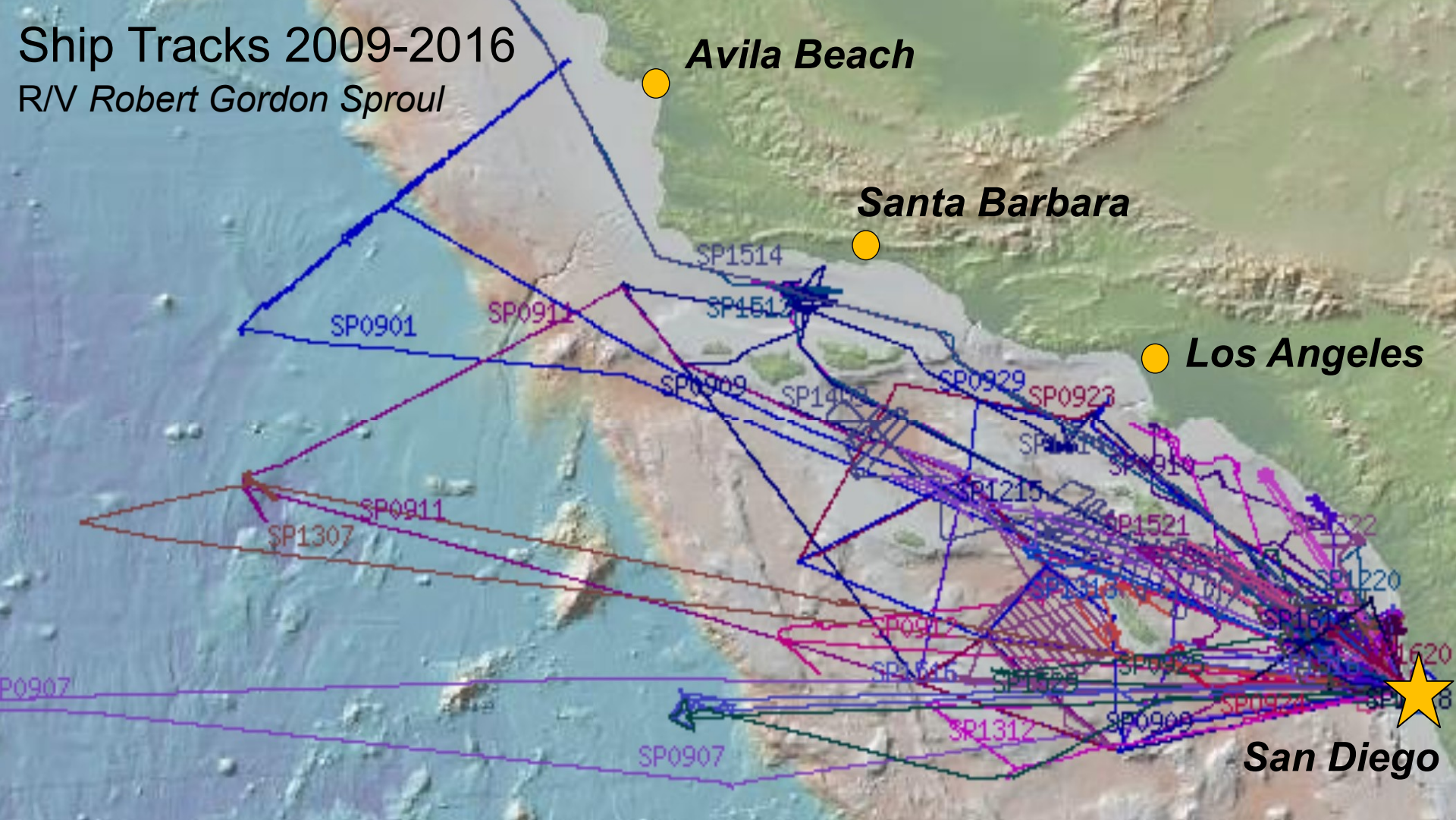

Ship Emissions Pollute All of Southern California

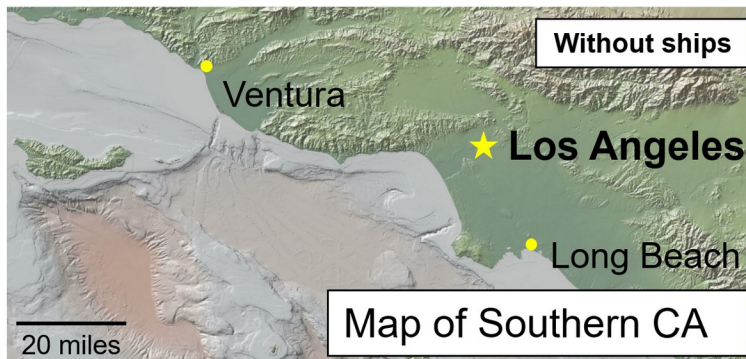

CARB recognizes diesel particulate matter as a **toxic air contaminant**.

Positive (dark) values show higher concentration due to ship emissions

“...diesel exhaust still poses substantial risks to public health and the environment.”

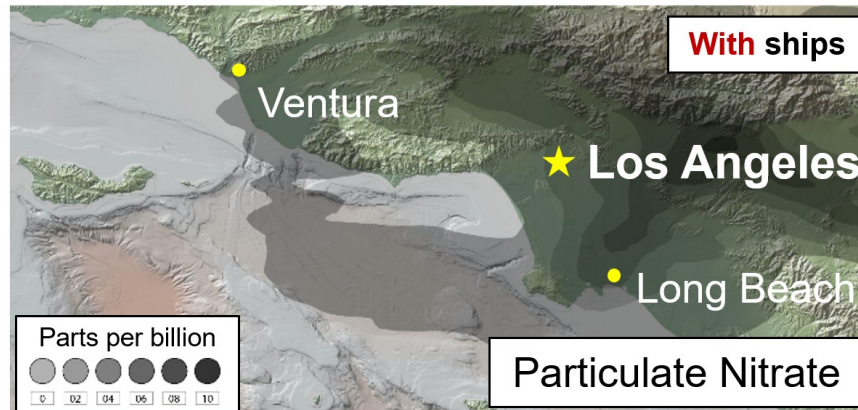
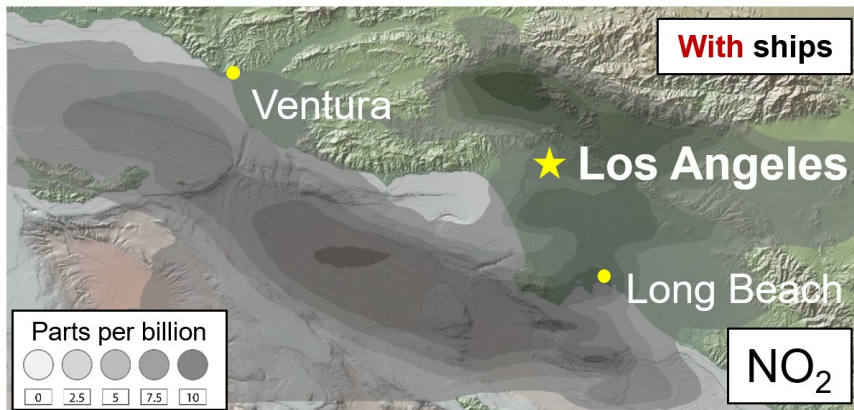



Solar power



Biodiesel & hull coatings



Electric vehicles



Stormwater



Clean power in port



Ballast water treatment

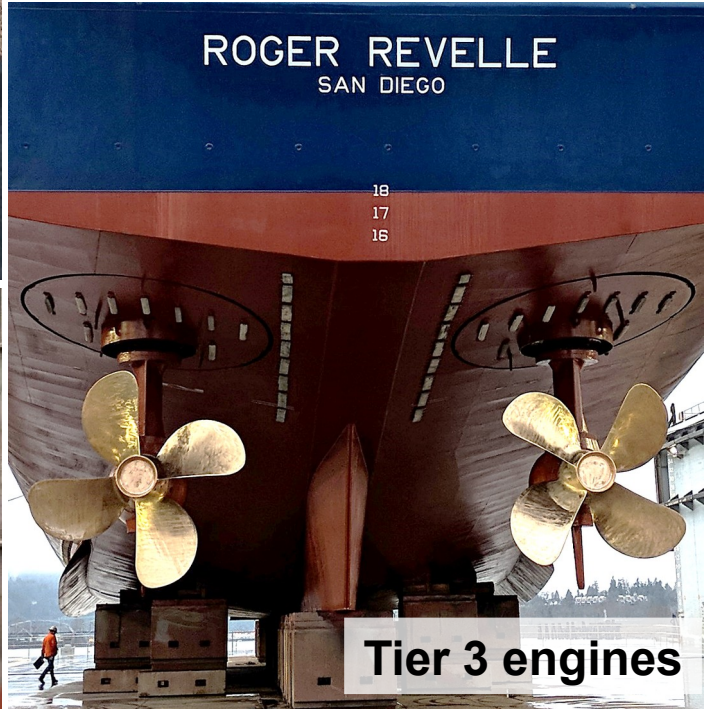

Tier 3 engines

ROGER REVELLE
SAN DIEGO

18
17
16

WHY A ZERO-EMISSION VESSEL?

University of California mission: Carbon neutrality by 2025

Scientific advantages

- Quiet = low underwater radiated sound
- Sample uncontaminated air and water
- Protects physical / biological systems
- Makes own ultrapure water

Environmental benefits relative to fossil fuels

- H₂ produced from renewable/sustainable sources
- No criteria pollutants, no greenhouse gas emissions
- **Hydrogen fuel spill cleans itself up in < 30 seconds**
- Quiet operations = low impact on marine wildlife
(also better for humans aboard)



Solar power



Hydrogen fuel cell

Feasibility Study: Can We Eliminate Ship Emissions?

SANDIA REPORT

SAND2019-4884 Unclassified Release | Printed May 2019

Feasibility of the Zero-V:

A Zero-Emission, Hydrogen Fuel-Cell, Coastal Research Vessel

Leonard E. Klebanoff, Joseph W. Pratt, Robert T. Madsen, Sean A.M. Caughlan, Timothy S. Leach, T. Bruce Appelgate, Jr., Stephen Zoltan Kelety, Hans-Christian Wintervoll, Gard Petra Haugson and Anthony T.Y. Teo

Prepared by
Sandia National Laboratories,
Livermore, California 94550

Sandia National Laboratories is a multimission laboratory managed and operated by National Technology and Engineering Solutions of Sandia, LLC, a wholly owned subsidiary of Honeywell International, Inc., for the U.S. Department of Energy's National Nuclear Security Administration under contract DE-NA0003525.



 Sandia National Laboratories



2018 Study:

Is it possible to build a capable non-polluting coastal research vessel that does not use fossil fuels, with existing technology that is available commercially now?

Answer: Yes

Download the full report:
maritime.sandia.gov

This work was supported by the U.S. Department of Transportation, Maritime Administration



Hydrogen fuel cells produce ZERO GHG or criteria emissions

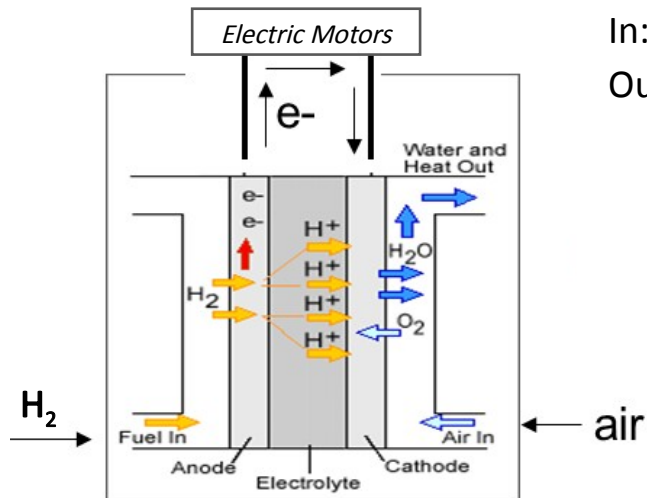

- Commercially available
- More energy efficient than diesel generators
- No emissions at the point of use
- Eliminates fuel spills, greatly reduces noise
- Emissions only arise from H₂ production/delivery

In: H₂ and air
Out: Electricity
Waste Heat
Warm humidified air



Emissions: Total impact from H₂ production and delivery

Well-To-Waves Criteria Emissions
(1,000 MT / year)

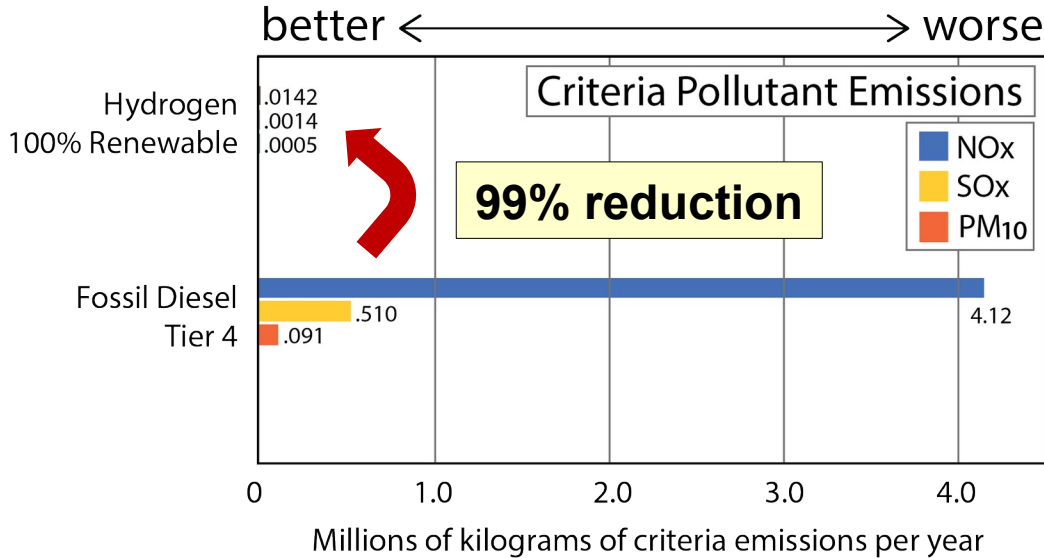

Well-to-Waves Greenhouse Gas Emissions
(1,000 MT CO₂ equivalent / year)

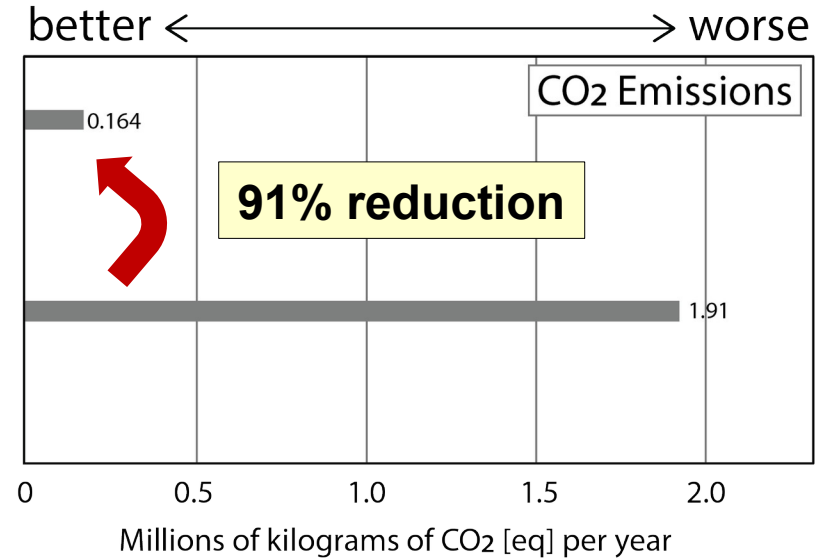

Criteria pollutant emissions can be reduced using LH₂. Dramatic reductions in GHG can be achieved with **renewable** LH₂. Renewable LH₂ is available now from commercial gas suppliers.

Fuel and bunkering: Safe and available at scale



Existing methods of LH₂ delivery

- Safe, proven practices
- Applicable to ship bunkering
- No major new shore infrastructure needed

Liquid hydrogen delivery at Emeryville, CA H₂ Station



Hydrogen is readily available at scale

- Mature supply chain
- LH₂ bunkering will require one trailer
- Full fuel transfer in < 4 hours

Decarbonizing requires clean hydrogen

- New **green hydrogen** production facility near San Diego coming on line 2023
- Electrolysis from solar, wind and nuclear electricity – no fossil fuels involved

A zero-emission research vessel is feasible NOW using existing technology

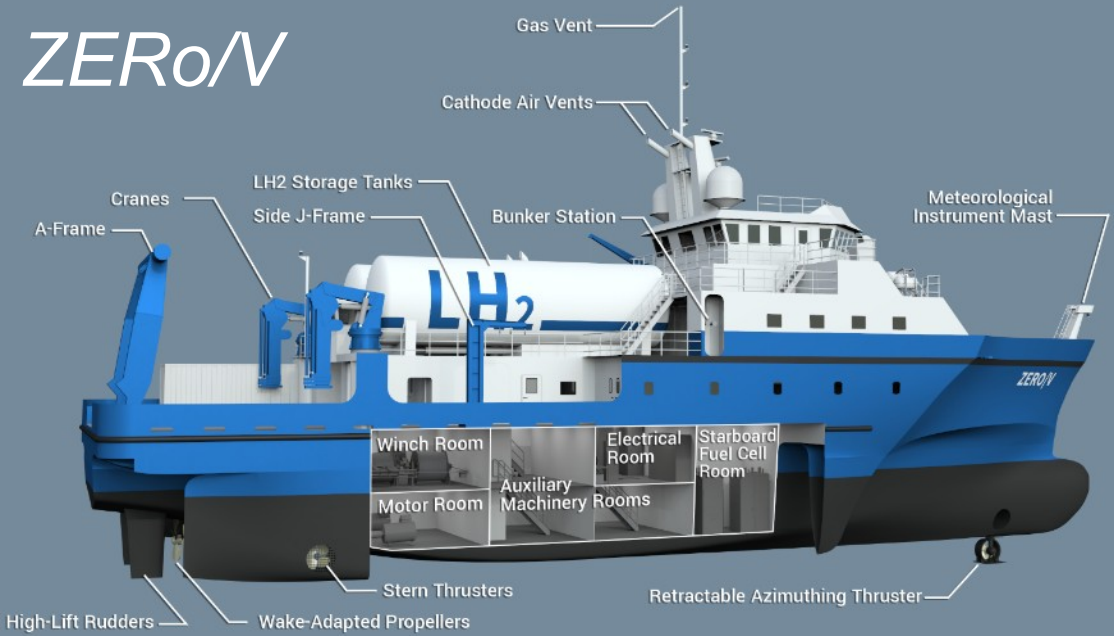

- Oceanographic research vessel for coastal / regional operations
- Uses clean hydrogen: **No fossil fuels!**
- Zero emissions: **Clean / no GHGs!**
- Carries no diesel: **No oil spills!**
- All-electric propulsion: **Quiet!**
- **FEASIBLE** with existing technology
- Outstanding scientific capabilities
- Advanced instrumentation
- Designed for California's educational and R&D needs

A bold, transformative game-changer

The zero-emission research vessel (ZERo/V) concept vessel has a range of 2,400 nm with berths for up to 20 scientists, supporting general-purpose missions.



What about a coastal vessel?

Can a coastal research vessel achieve zero emissions using hydrogen fuel cells or batteries, coupled with conventional propulsion?

Goals of 2020 study:

Design one hull, and use it to compare four different power systems:

- **Baseline Vessel:** conventional diesel-electric propulsion.
- **Battery Hybrid Vessel:** diesel-electric plus lithium-ion battery bank.
- **H₂ Hybrid Vessel:** diesel-electric plus H₂/Fuel Cell
- **All Hydrogen Vessel:** 100% H₂/Fuel Cell propulsion



Science mission requirements, along the entire CA Coast

Cruise speed	10 knots
Max speed	11 knots
Range	2,400 nm
Endurance	10 days
Students	30 (min) 40 (desired)
Crew berths	5 (singles preferred)
Science berths	12 (min)
Stationkeeping	Dynamic positioning
Lab area	340 ft ² (min)
Deck sockets	UNOLS compliant
Main crane	2,400 lbs SWL
Stern A-Frame	21,000 lbs SWL
Side Frame	10,000 lbs SWL
Winches	Trawl, CTD/Hydro
Sewage holding	2,000 gal (min)
Portable vans	2 (min)
Scientific instrumentation: sonar suite, GPS, motion reference, satcom broadband, network	

Historical Range

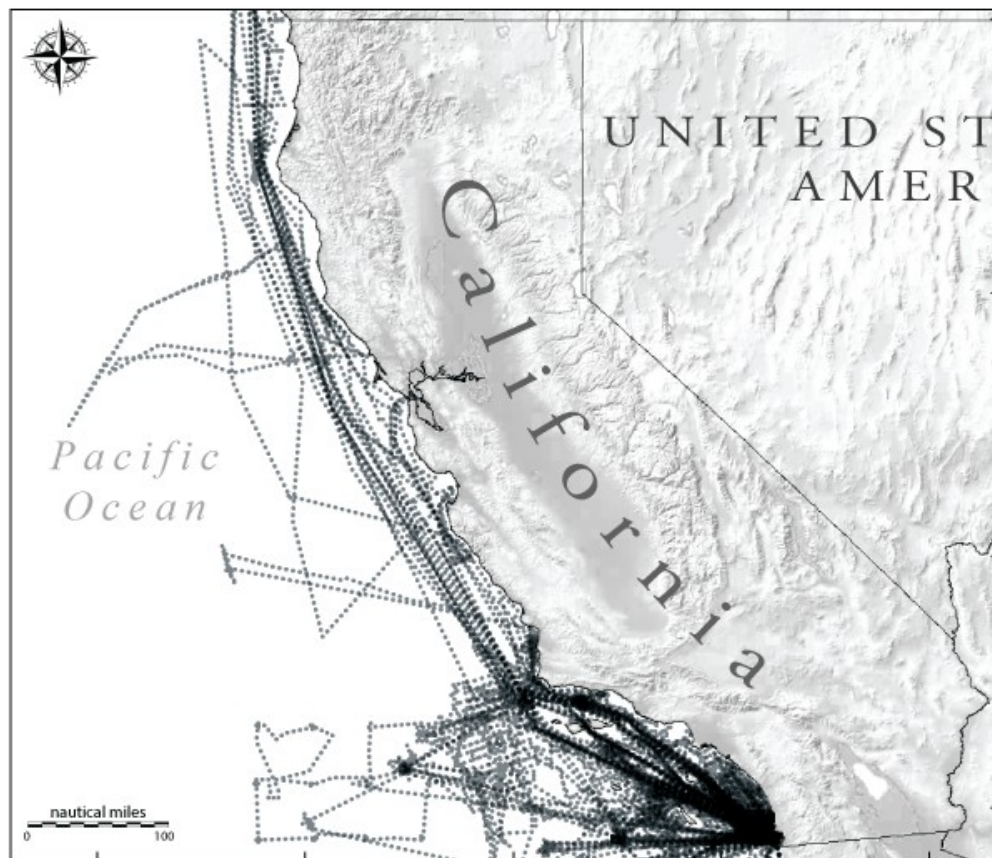

Science instrumentation

General multi-purpose research vessel

- High frequency ADCP
- Medium frequency ADCP
- 12kHz transducer
- Expendable bathythermograph
- GPS/GNSS x2
- Multibeam sonar
- Sub-bottom profiler
- Sonar synchronization unit
- Fisheries imaging sonar
- USBL positioning system
- Meteorological system sensors
- Underway seawater system sensors
- Portable transducer pipe string
- Universal acoustic deck box
- Computing cluster & storage array
- Network security (switches, firewalls)
- Scientific system display array
- Satcoms: Dual GX100 HP NX systems
- Cellular internet integration
- AIS antenna
- Radio direction finder / receiver

Hybrid approach to maritime power system

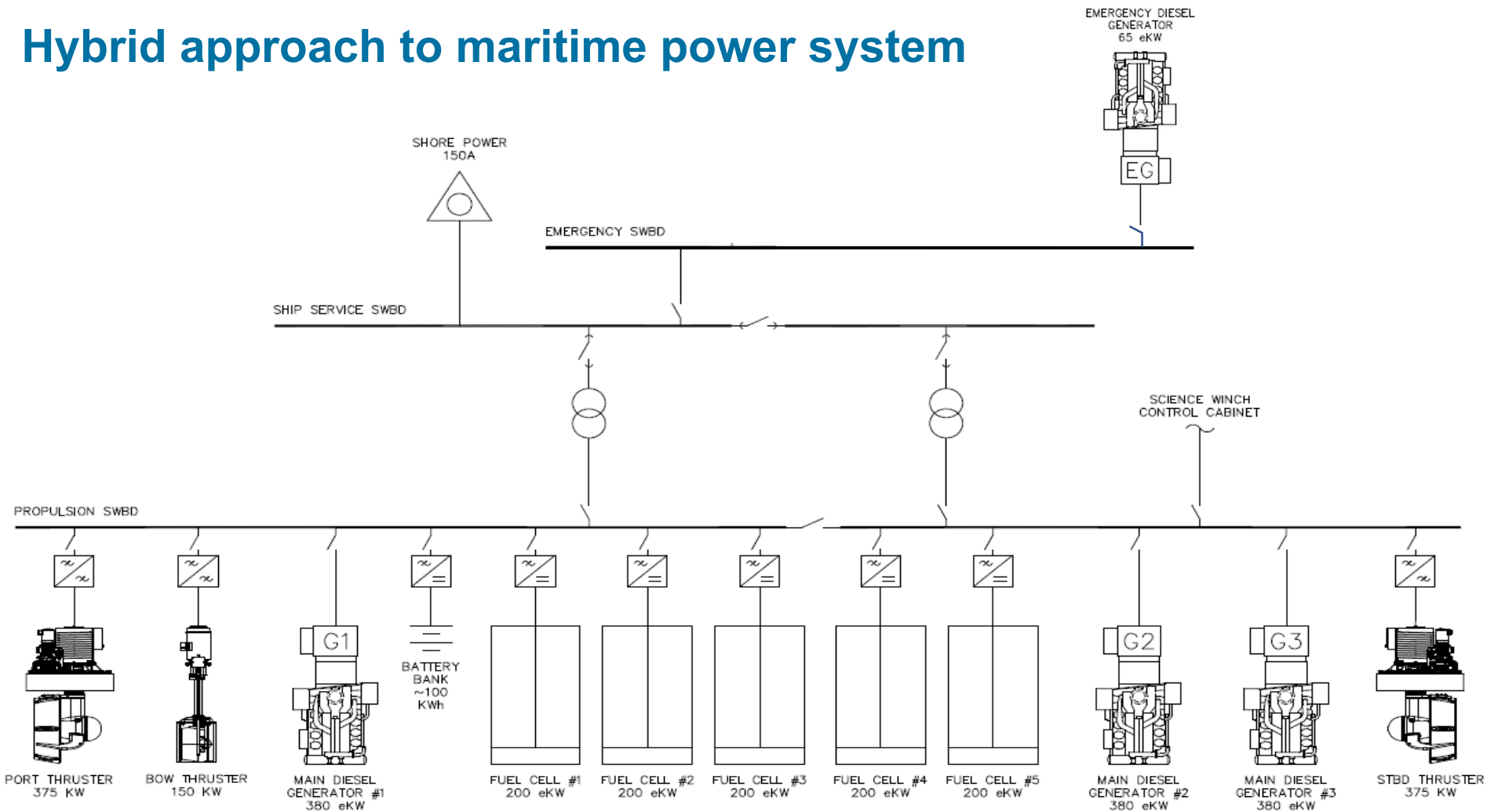

Hybrid Variants: Battery vs Hydrogen

Hydrogen hybrid is better than batteries

Cruise Speed	Zero Emissions Range (NM)	
	Battery Hybrid	Hydrogen Hybrid
9 knots	37	330
10 knots	25	234

75% of missions can be zero-emissions using hydrogen --- **fossil free**

Compared to batteries, the Hydrogen Hybrid offers:

- ✓ 9x better zero-emission range & endurance
- ✓ Commensurate reductions in NOx, HC, PM and GHGs
- ✓ Better suited for ocean-going ships with long missions



Students And Scientists Loved This Idea

A Petition for Scripps's Commitment to a Zero-Emission Research Fleet.

The signers of this petition request that Scripps Institution of Oceanography makes a **commitment to transitioning the Scripps Research Vessel Fleet** to a fleet of **Zero-Emission Research Vessels**. Scripps is a world leader in research about the oceans, earth, and climate. This research has revealed the importance of environmental stewardship for the wellbeing of people and the planet. In pursuit of groundbreaking research, Scripps operates a fleet of research vessels that have proven to be invaluable

June 2021

- Signed by more than 125 students, scientists and organizations at SIO
- Called on SIO to commit to transitioning all our research vessels to zero-emission propulsion systems

Environmental justice

AB 617 Portside Steering Committee

“The Portside Environmental Justice Steering Committee (Portside Committee) supports Scripps hydrogen-hybrid coastal research vessel project....”

...This vessel will advance the Portside Committee’s efforts to reduce criteria pollutants and greenhouse gas emissions from ships, while demonstrating the viability of clean, nonpolluting zero-emission shipboard power systems to the maritime industry.

“Bold and transformational solutions such as this are urgently needed to improve the health of the Portside Community by reducing and eliminating emissions from port-related activities.”



The San Diego Union-Tribune

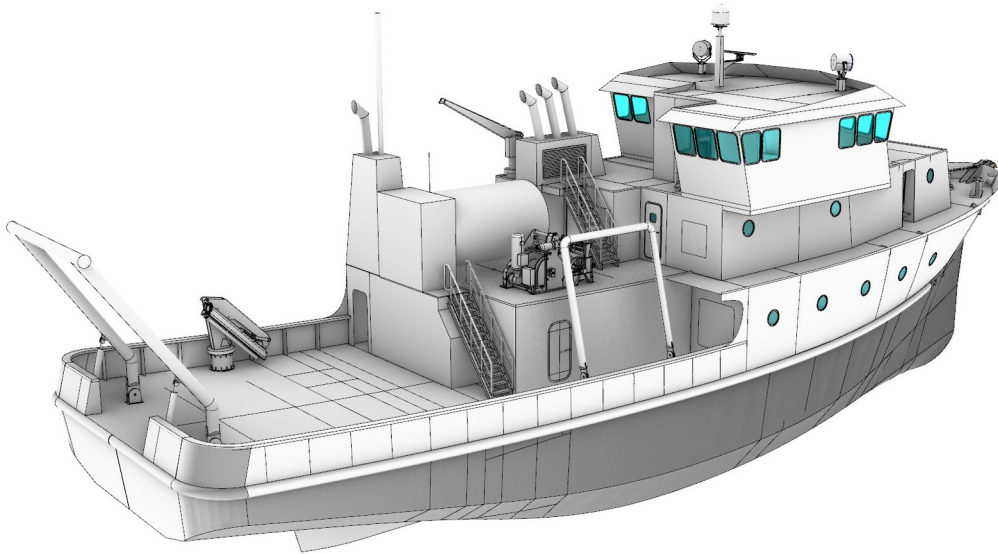

Jul 23, 2021

UC SAN DIEGO RECEIVES \$35 MILLION IN STATE FUNDING FOR NEW CALIFORNIA COASTAL RESEARCH VESSEL

First-of-its-kind hydrogen-hybrid vessel will be vital to education and research

California Budget Act of 2021

On 12 July 2021, Governor Newsom signed SB 129, which contained one-time appropriations to Scripps, for a hydrogen hybrid research vessel

Design & Construction Timeline

Phase I: Detailed engineering, design, review, and prep

- 2021: Establish project office at Scripps, issue RFI and RFP for design (complete)
- 2022: Development of detailed vessel engineering and design (underway)
- 2023: Final engineering review and construction prep

Phase II: Construction

- 2024: Keel laying and construction

Phase III: Commission for service

- 2026: Christening, sea trials, delivery, verification
- 2027: Begin regular operations in Q1

